

金輪牌工業用縫紉機  
GOLDEN WHEEL INDUSTRIAL SEWING MACHINE

零件分解圖

PARTS BOOK  
MODEL: CSU-4150  
CSU-4250

啟翔股份有限公司  
CHEE SIANG INDUSTRIAL CO., LTD.

# MODEL : CSU-4150 CSU-4250

索引	INDEX	PAGE
A. 本體機構	ARM BED AND ITS ACCESSORIES	2 - 3
B. 縫線壓力調整機構	UPPER THREAD TENSION REGULATOR MECHANISM	4 - 5
C. 上軸機構	UPPER SHAFT MECHANISM	6 - 7
D. 針棒 . 天秤機構	NEEDLE BAR AND TAKE-UP LEVER MECHANISM	8 - 9
E. 針棒搖擺機構	NEEDLE BAR ROCKING MECHANISM	10 - 11
F. 押棒機構	PRESSER FOOT BAR MECHANISM	12 - 13
G. 上部送料機構	FEED ROTATING SHAFT MECHANISM	14 - 15
H. 縫目調整器機構	STITCH REGULATOR MECHANISM	16 - 17
I. 左右送料機構	ZIGZAG FEED MECHANISM	18 - 19
J. 釜機構	ROTARY HOOK MECHANISM	20 - 21
K. 下軸機構	LOWER SHAFT MECHANISM	22 - 23
L. 油潤滑機構	OIL LUBRICATION MECHANISM	24 - 25
M. 附件	ACCESSORIES	26 - 29
N. CSU-4250 針位圖號詳表	GAUGE PARTS LIST	30
O. 零件號碼與頁數對照表	NUMERICAL PARTS-LIST	31 - 33

A.CSU-4150・CSU-4250 本體機構 ARM BED AND ITS ACCESSORIES

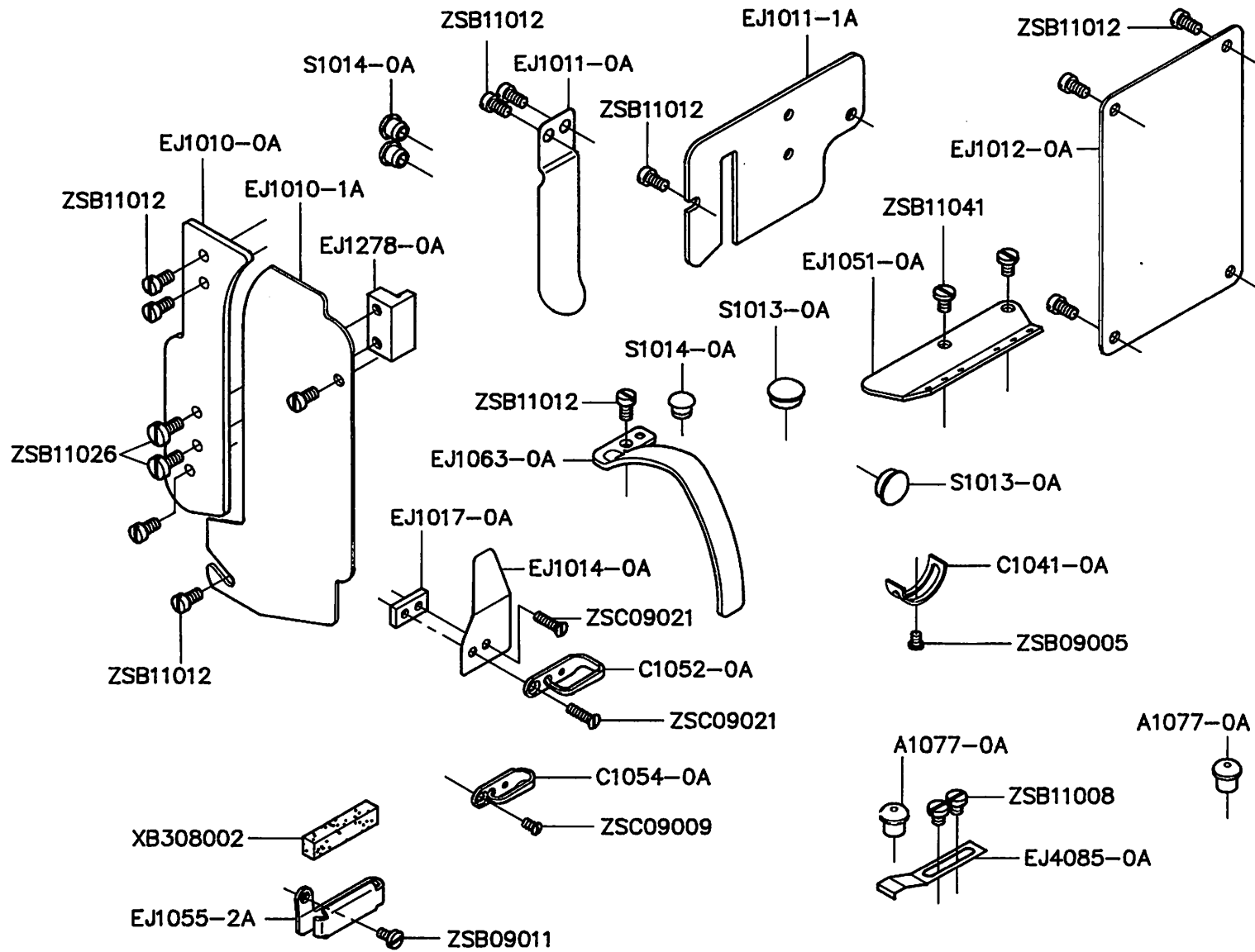

A. CSU-4150.CSU-4250 本體機構 ARM BED AND ITS ACCESSORIES

零件號碼 Part No.	零件名稱	Name of Part	件數 4150	Q'TY 4250	備註 Remarks
A1077-0A	油蓋	Needle Bar Upper Bushing Cap	2	2	
C1041-0A	線軸彈簧調整器	Stopper	1	1	
C1052-0A	線掛	Arm Thread Guide	1	1	
C1054-0A	線掛	Arm Thread Guide	1	1	
EJ1010-0A	面板	Face Plate	1	1	
EJ1010-1A	面板	Face Plate	1	1	
EJ1011-0A	側板 (前)	Arm Cover (Front)	1	1	
EJ1011-1A	側板 (中)	Arm Cover (Middle)	1	1	
EJ1012-0A	側板 (後)	Arm Cover (Back)	1	1	
EJ1014-0A	擋油板	Oil Guard Plate	1	1	
EJ1017-0A	螺帽板	Specer	1	1	
EJ1051-0A	四孔線掛	4 Hole Thread Retainer	1	1	
EJ1055-2A	線掛	Arm Thread Guide	1	1	
EJ1063-0A	天秤蓋	Thread Take-up Cover	1	1	
EJ1278-0A	定位板	Bell Crank Guide	1	1	
EJ4085-0A	彈簧片	Bed Slide Spring	1	1	
S1013-0A	油塞	Oil Cap	2	2	
S1014-0A	橡膠塞	Cap	3	3	
XB308002	油棉	Oil Felt	1	1	
ZSB09005	螺絲	Screw (9/64-40×5)	1	1	
ZSB09011	螺絲	Screw (9/64-40×6.5)	1	1	
ZSB11008	螺絲	Screw (11/64-40×5)	2	2	
ZSB11012	螺絲	Screw (11/64-40×8)	14	14	
ZSB11026	螺絲	Screw (11/64-40×10)	2	2	
ZSB11041	螺絲	Screw (11/64-40×7)	2	2	
ZSC09009	螺絲	Screw (9/64-40×5)	1	1	
ZSC09021	螺絲	Screw (9/64-40×13)	2	2	



B. CSU-4150.CSU-4250 縫線壓力調整機構 UPPER THREAD TENSION REGULATOR MECHANISM

零件號碼 Part No.	零件名稱	Name of Part	件數 4150	Q'TY 4250	備註 Remarks
A1024-1A	過線盤組	Tension Regulator Bracket	1	2	
A1026-1A	壓力調整螺絲棒	Thread Tension Stud	1	1	
A1026-3A	壓力調整螺絲棒	Thread Tension Stud	0	1	
A1030-0A	過線孔台	Thread Guide Bracket	1	2	
A1031-0A	過線孔圓盤	Thread Guide Disc	1	2	
A1032-0A	壓力彈簧	Thread Tension Spring	1	2	
A1033-0A	過線孔內蓋	Controller Cover	1	2	
A1034-0A	壓力調整器壓盤	Tension Regulator Presser Disc	1	2	
A1035-0A	壓線盤	Tension Disc	2	4	
A1036-0A	壓板彈簧	Tension Releasing Spring	1	1	
A1038-0A	上線壓力板	Upper Thread Tension Plate	1	1	
EJ1020-0A	縫線壓力調整組	Thread Tension Regulator Assy.	1	0	
EJ1020-1A	縫線壓力調整組	Thread Tension Regulator Assy.	0	1	
EJ1021-0A	調整彈簧	Tension Spring	1	2	
EJ1026-0A	調整螺絲桿	Thread Tension Stud	1	0	
EJ1026-2A	調整螺絲桿	Thread Tension Stud	0	1	
EJ1027-0A	吊線彈簧	Thread Take-up Spring	1	0	
EJ1027-1A	吊線彈簧	Thread Take-up Spring	0	1	
EJ1028-0A	鬆線銷	Tension Releasing Pin	1	1	
EJ1028-2A	鬆線銷	Tension Releasing Pin	0	1	
EJ1037-0A	彈簧板	Tension Releasing Plate	1	1	
EJ1043-0A	鬆線銷	Tension Releasing Pin	1	1	
ZSB06001	螺絲	Screw (3/32-56×6.3)	1	0	
ZSB06003	螺絲	Screw (3/32-56×12)	0	1	
ZSB09007	螺絲	Screw (9/64-40×7.5)	1	1	
ZSB11012	螺絲	Screw (11/64-40×8)	1	1	
ZSG09004	螺絲	Screw (9/64-40)	2	2	
ZSG09005	螺絲	Screw (9/64-40)	1	2	
ZSL09001	螺帽	Nut (9/64-40×3)	1	2	
ZSN16002	螺帽	Nut (1/4-40×5)	2	3	

C. CSU-4150·CSU-4250 上軸機構 UPPER SHAFT MECHANISM

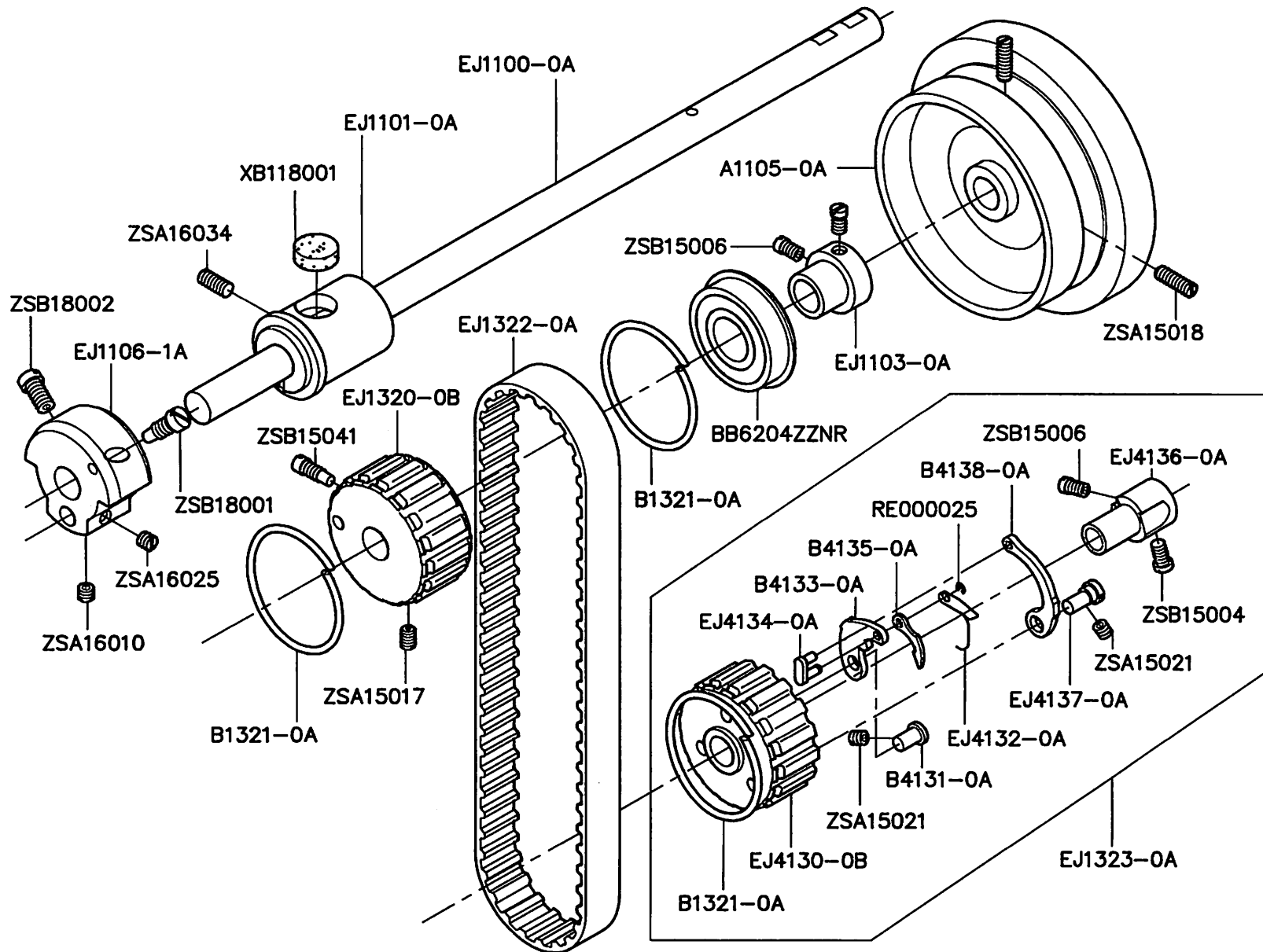

C. CSU-4150.CSU-4250 上軸機構 UPPER SHAFT MECHANISM

零件號碼 Part No.	零件名稱	Name of Part	件數 4150	Q'TY 4250	備註 Remarks
A1105-0A	皮帶輪	Pulley	1	1	
B1321-0A	齒輪邊環	Side Ring	3	3	
B4131-0A	固定銷	Safety Clutch Locking Lever Hinge Stud	1	1	
B4133-0A	離合器板	Safety Clutch Locking Lever	1	1	
B4135-0A	離合器棘輪	Safety Clutch Ratchet	1	1	
B4138-0A	離合器彈簧板	Safety Clutch Locking Lever Flat Spring	1	1	
BB6204ZZNR	滾珠軸承	Ball Bearing	1	1	
EJ1100-0A	上軸	Upper Shaft	1	1	
EJ1101-0A	上軸套管(左)	Upper Shaft Bushing,(Left)	1	1	
EJ1103-0A	上軸套管(右)	Upper Shaft Bushing,(Right)	1	1	
EJ1106-1A	凸輪	Crank Cam	1	1	
EJ1320-0B	齒形皮帶輪(上)	Timing Belt Wheel (Upper)	1	1	
EJ1322-0A	齒形皮帶	Timing Belt	1	1	
EJ1323-0A	離合器組	Safety Clutch	1	1	
EJ4130-0B	齒形皮帶輪	Safety Clutch Pulley	1	1	
EJ4132-0A	離合器彈簧	Safety Clutch Locking Lever Spring	1	1	
EJ4134-0A	連接板	Safety Clutch Ratchet Connecting Link	1	1	
EJ4136-0A	離合器套環	Safety Clutch Collar	1	1	
EJ4137-0A	固定銷	Pin	1	1	
RE000025	E形扣環	E-Ring	1	1	
XB118001	油棉	Felt	1	1	
ZSA15017	螺絲	Screw (15/64-28×8.5)	1	1	
ZSA15018	螺絲	Screw (15/64-28×19)	2	2	
ZSA15021	螺絲	Screw (15/64-28×4.5)	2	2	
ZSA16010	螺絲	Screw (1/4-40×4.5)	1	1	
ZSA16025	螺絲	Screw (1/4-40×6)	1	1	
ZSA16034	螺絲	Screw (1/4-24×14)	1	1	
ZSB15004	螺絲	Screw (15/64-28×10.5)	1	1	
ZSB15006	螺絲	Screw (15/64-28×8.5)	3	3	
ZSB15041	螺絲	Screw (15/64-28×9)	1	1	
ZSB18001	螺絲	Screw (9/32-28×16)	1	1	
ZSB18002	螺絲	Screw (9/32-28×13)	1	1	



D. CSU-4150・CSU-4250 針棒、天平機構 NEEDLE BAR AND TAKE-UP LEVER MECHANISM

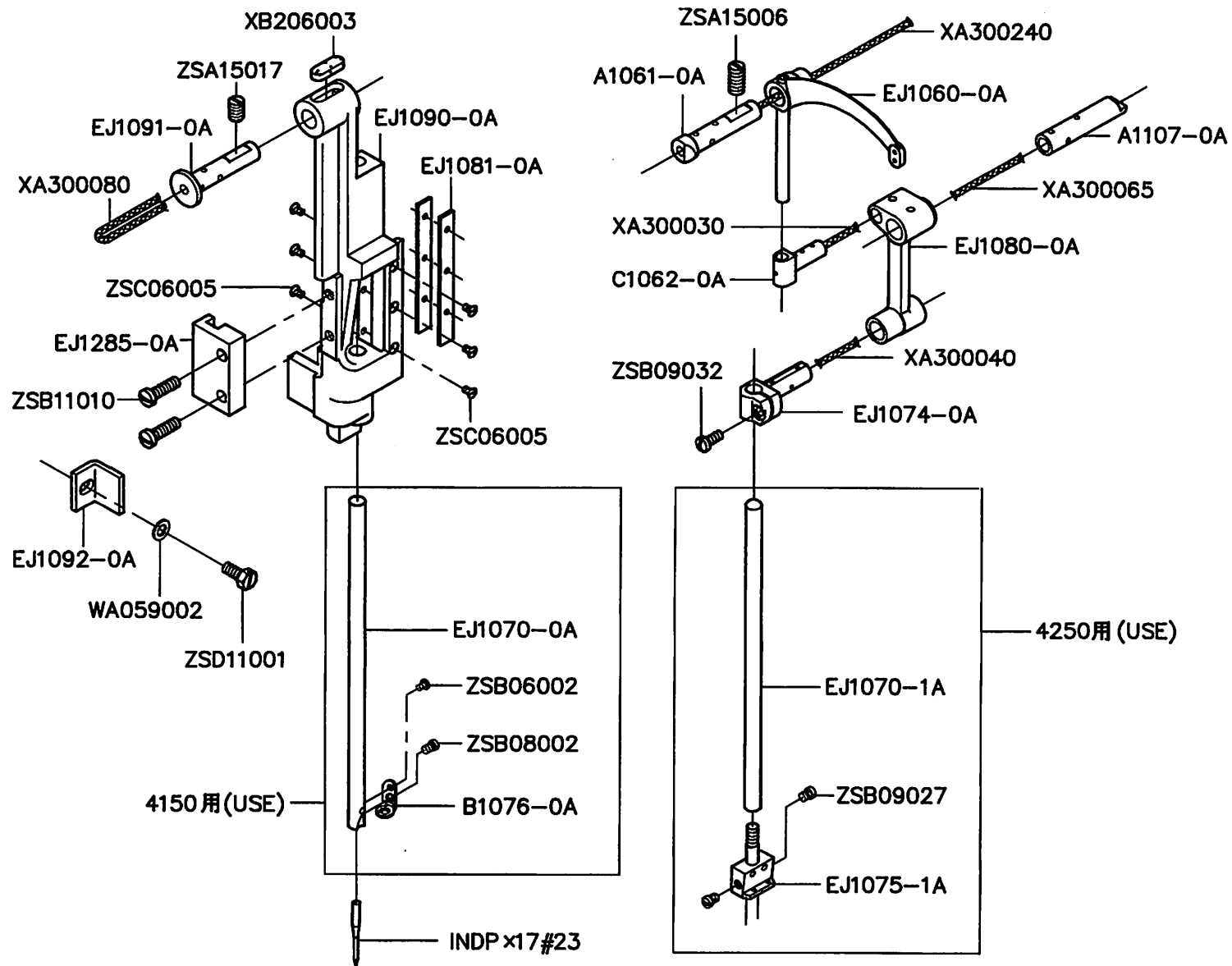

D. CSU-4150.CSU-4250 針棒.天秤機構 NEEDLE BAR AND TAKE-UP LEVER MECHANISM

零件號碼 Part No.	零件名稱	Name of Part	件數 4150	Q'TY 4250	備註 Remarks
A1061-0A	天秤固定銷	Take-up Lever Support Stud	1	1	
A1107-0A	凸輪固定銷	Crank Pin	1	1	
B1076-0A	針棒線掛	Thread Guide	1	0	
C1062-0A	天秤滑塊	Take-up Slide Block	1	1	
EJ1060-0A	天秤	Thread Take-up Lever	1	1	
EJ1070-0A	針棒	Needle Bar	1	0	
EJ1070-1A	針棒	Needle Bar	0	1	
EJ1074-0A	針棒鉗	Needle Bar Clamp	1	1	
EJ1075-1A	針榴	Needle Clamp	0	1	
EJ1080-0A	針棒連接器	Needle Bar Crank Rod	1	1	
EJ1081-0A	針棒滑板	Needle Bar Slide Plate	2	2	
EJ1090-0A	針棒座	Needle Bar Support Frame	1	1	
EJ1091-0A	針棒座固定軸	Needle Bar Frame Support Stud	1	1	
EJ1092-0A	針棒座固定板	Needle Bar Frame Retainer	1	1	
EJ1285-0A	針棒定位座	Vibrating Presser Bar Guide	1	1	
INDP×17#23	針	Needle	1	2	
WA059002	平墊圈	Washer	1	1	
XA300030	油線	Wick	1	1	
XA300040	油線	Wick	1	1	
XA300065	油線	Wick	1	1	
XA300080	油線	Wick	1	1	
XA300240	油線	Wick	1	1	
XB206003	油棉	Felt	1	1	
ZSA15006	螺絲	Screw (M4×0.7×8)	1	1	
ZSA15017	螺絲	Screw (M4×0.7×6)	1	1	
ZSB06002	螺絲	Screw (3/32-56×2.5)	1	0	
ZSB08002	螺絲	Screw (1/8-44×4.5)	1	0	
ZSB09027	螺絲	Screw (9/64-40×4)	0	2	
ZSB09032	螺絲	Screw (9/64-40×8.5)	1	1	
ZSB11010	螺絲	Screw (11/64-40×14)	2	2	
ZSC06005	螺絲	Screw (3/32-56×4.2)	6	6	
ZSD11001	螺絲	Screw (11/64-40×9.5)	1	1	

E. CSU-4150、CSU-4250 針棒搖擺機構 NEEDLE BAR ROCKING MECHANISM

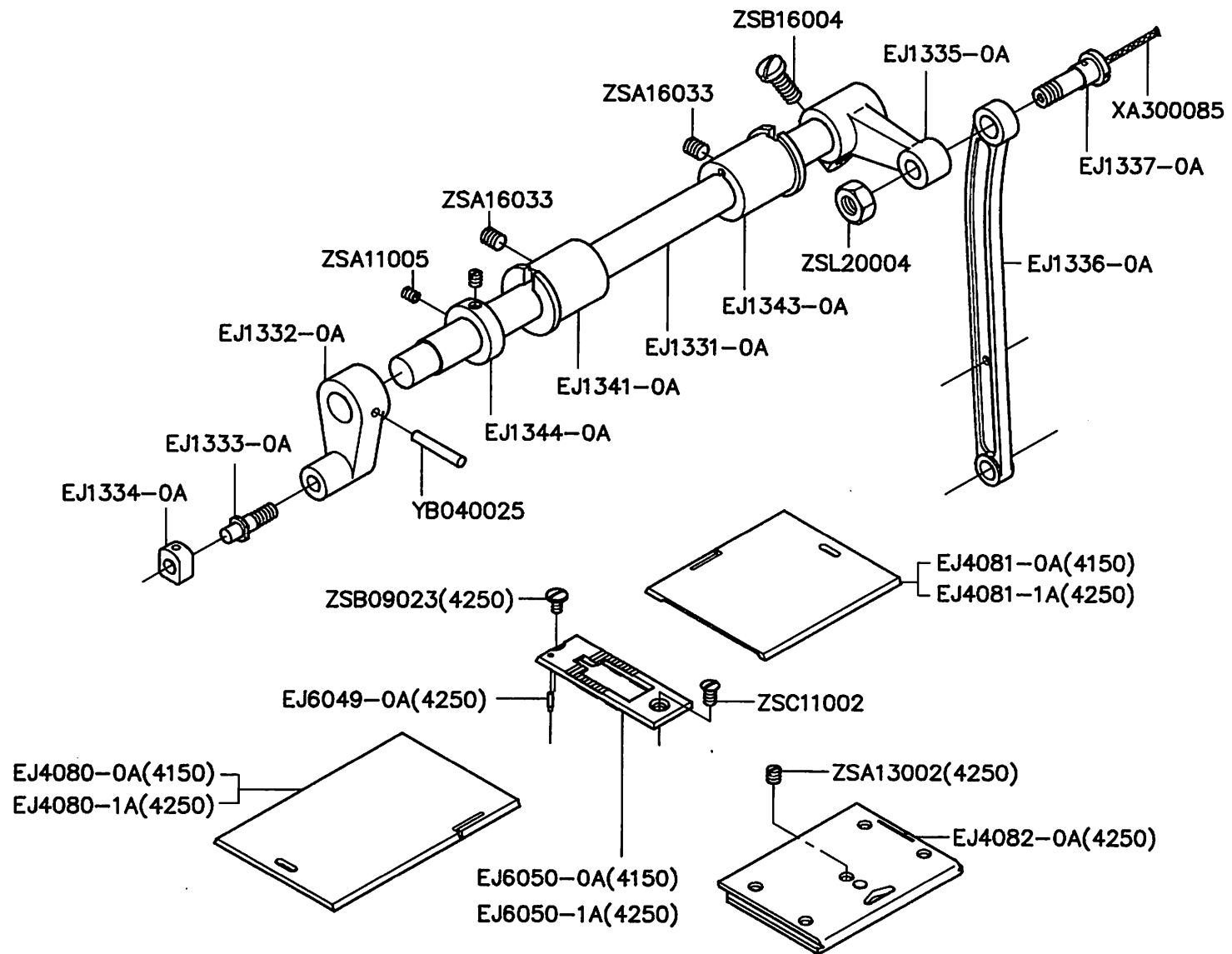

E. CSU-4150.CSU-4250 針棒搖擺機構 NEEDLE BAR ROCKING MECHANISM

零件號碼 Part No.	零件名稱	Name of Part	件數 4150	Q'TY 4250	備註 Remarks
EJ1331-0A	針棒搖桿軸	Needle Bar Rock Shaft	1	1	
EJ1332-0A	針棒擺動臂(左)	Needle Bar Connecting Rod (Left)	1	1	
EJ1333-0A	針棒擺動滑塊軸	Needle Bar Rock Frame Slide Block Stud	1	1	
EJ1334-0A	針棒擺動滑塊	Needle Bar Guide Slide Block	1	1	
EJ1335-0A	針棒擺動臂(右)	Needle Bar Connecting Rod (Right)	1	1	
EJ1336-0A	針棒擺動連桿	Needle Bar Rock Link	1	1	
EJ1337-0A	連桿固定螺栓	Needle Bar Rock Link Stud	1	1	
EJ1341-0A	針搖桿軸套管(左)	Needle Bar Rock Shaft Bushing, (Left)	1	1	
EJ1343-0A	針搖桿軸套管(右)	Needle Bar Rock Shaft Bushing, (Right)	1	1	
EJ1344-0A	固定環	Collar	1	1	
EJ4080-0A	角板(左)	Slide Plate, (Left)	1	0	
EJ4080-1A	角板(左)	Slide Plate, (Left)	0	1	
EJ4081-0A	角板(右)	Slide Plate, (Right)	1	0	
EJ4081-1A	角板(右)	Slide Plate, (Right)	0	1	
EJ4082-0A	角板(前)	Slide Plate Front Assembly	0	1	
EJ6049-0A	針板定位銷	Pin	0	1	
EJ6050-0A	針板	Needle Plate	1	0	
EJ6050-1A	針板	Needle Plate	0	1	
XA300085	油線	Wick	1	1	
YB040025	推拔銷	Taper Pin	1	1	
ZSA11005	螺絲	Screw (11/64-40×5.5)	2	2	
ZSA13002	螺絲	Screw (13/64-32×4.2)	0	1	
ZSA16033	螺絲	Screw (1/4-24×7.5)	2	2	
ZSB09023	螺絲	Screw (9/64-40×7)	0	1	
ZSB16004	螺絲	Screw (1/4-24×16)	1	1	
ZSC11002	螺絲	Screw (11/64-40×9)	2	1	
ZSL20004	螺帽	Nut (5/16-24×7)	1	1	

F. CSU-4150、CSU-4250 押棒機構 PRESSER FOOT BAR MECHANISM

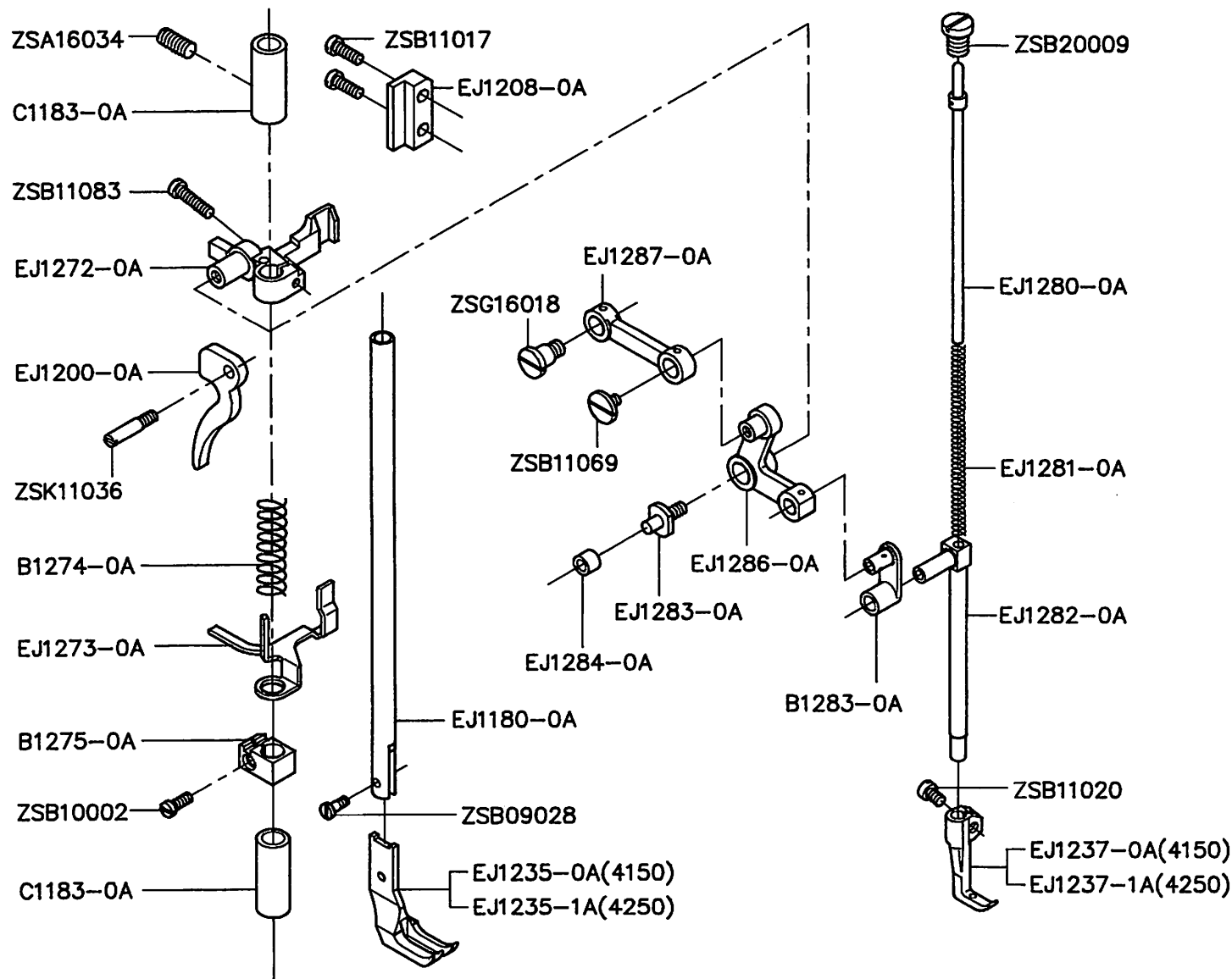

F. CSU-4150.CSU-4250 押棒機構 PRESSER FOOT BAR MECHANISM

零件號碼 Part No.	零件名稱	Name of Part	件數 4150	Q'TY 4250	備註 Remarks
B1274-0A	壓縮彈簧	Spring	1	1	
B1275-0A	押棒固定座	Presser Bar Bracket	1	1	
B1283-0A	押腳舉升連桿	Vibrating Presser Bar Connecting Link	1	1	
C1183-0A	押棒套管	Presser Bar Bushing,	2	2	
EJ1180-0A	押棒	Presser Bar	1	1	
EJ1200-0A	押腳提桿	Presser Foot Lifter	1	1	
EJ1208-0A	定位板	Position Plate	1	1	
EJ1235-0A	外押腳	Walking Foot	1	0	
EJ1235-1A	外押腳	Walking Foot	0	1	
EJ1237-0A	內押腳	Presser Foot	1	0	
EJ1237-1A	內押腳	Presser Foot	0	1	
EJ1272-0A	押棒提昇器	Presser Bar Lifter	1	1	
EJ1273-0A	鬆線導板	Tension Release Slide	1	1	
EJ1280-0A	彈簧導桿組	Spring Guide Bar Complete	1	1	
EJ1281-0A	壓縮彈簧	Spring	1	1	
EJ1282-0A	押腳引導桿	Walking Foot Guide Link	1	1	
EJ1283-0A	固定銷	Pin	1	1	
EJ1284-0A	導塊	Bell Crank Guide Bracket Block	1	1	
EJ1286-0A	L型連桿	Bell Crank	1	1	
EJ1287-0A	舉升搖軸連桿	Feed Lifting Rock Shaft Link	1	1	
ZSA16034	螺絲	Screw (1/4-24×14)	1	1	
ZSB09028	螺絲	Screw (9/64-40×8.7)	1	1	
ZSB10002	螺絲	Screw (5/32-40×9)	1	1	
ZSB11017	螺絲	Screw (11/64-40×12)	2	2	
ZSB11020	螺絲	Screw (11/64-40×6.5)	1	1	
ZSB11069	螺絲	Screw (11/64-40×6)	1	1	
ZSB11083	螺絲	Screw (11/64-40×18)	1	1	
ZSB20009	螺絲	Screw (5/16-28×10)	1	1	
ZSG16018	螺絲	Screw (1/4-40)	1	1	
ZSK11036	螺絲	Screw (11/64-40)	1	1	

G. CSU-4150・CSU-4250 上部送料機構 FEED ROTATING SHAFT MECHANISM

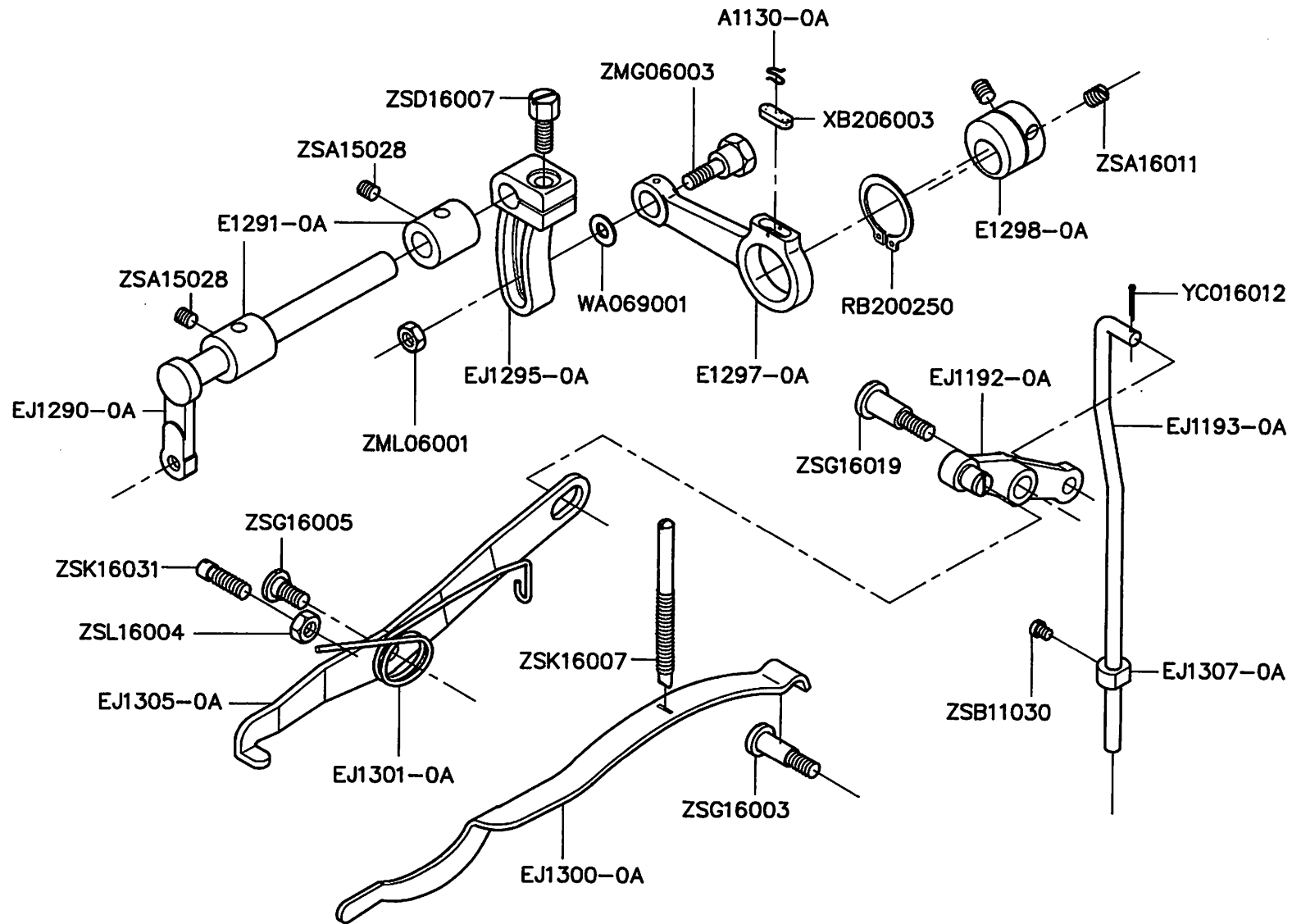

G. CSU-4150.CSU-4250 上部送料機構 FEED ROTATING SHAFT MECHANISM

零件號碼 Part No.	零件名稱	Name of Part	件數 Q'TY		備註 Remarks
			4150	4250	
A1130-0A	油棉固定彈簧	Spring	1	1	
E1297-0A	連桿	Connection Rod	1	1	
E1298-0A	偏心輪	Eccentric Cam	1	1	
EJ1192-0A	腳弓槓桿	Knee Lifter Lever	1	1	
EJ1193-0A	連接桿	Knee Lifter Connecting Rod	1	1	
EJ1290-0A	上送軸	Feed Rotating Shaft	1	1	
EJ1291-0A	上送軸套管	Feed Rotating Shaft Bushing	2	2	
EJ1295-0A	上送軸曲柄	Feed Rotating Shaft Crank	1	1	
EJ1300-0A	壓軸平彈簧	Presser Bar Flat Spring	1	1	
EJ1301-0A	彈簧	Spring	1	1	
EJ1305-0A	押腳抬高桿	Foot Lifter Lifting Lever	1	1	
EJ1307-0A	固定環	Set Collar	1	1	
RB200250	C形扣環(軸用)	Retaining Ring	1	1	
WA069001	平墊圈	Washer	1	1	
XB206003	油棉	Oil Felt	1	1	
YC016012	開口銷	Pin	1	1	
ZMG06003	螺絲	Screw (M6×1.0)	1	1	
ZML06001	螺帽	Nut (M6×1.0×4.8)	1	1	
ZSA15028	螺絲	Screw (15/64-28×7)	2	2	
ZSA16011	螺絲	Screw (1/4-40×7)	2	2	
ZSB11030	螺絲	Screw (11/64-40×5.5)	1	1	
ZSD16007	螺絲	Screw (1/4-28×18)	1	1	
ZSG16003	螺絲	Screw (1/4-24)	1	1	
ZSG16005	螺絲	Screw (1/4-24)	1	1	
ZSG16019	螺絲	Screw (1/4-24)	1	1	
ZSK16007	螺絲	Screw (1/4-28)	1	1	
ZSK16031	螺絲	Screw (1/4-24)	1	1	
ZSL16004	螺帽	Nut (1/4-24×5)	1	1	



H.CSU-4150·CSU-4250 縫目調整器機構 STITCH REGULATOR MECHANISM

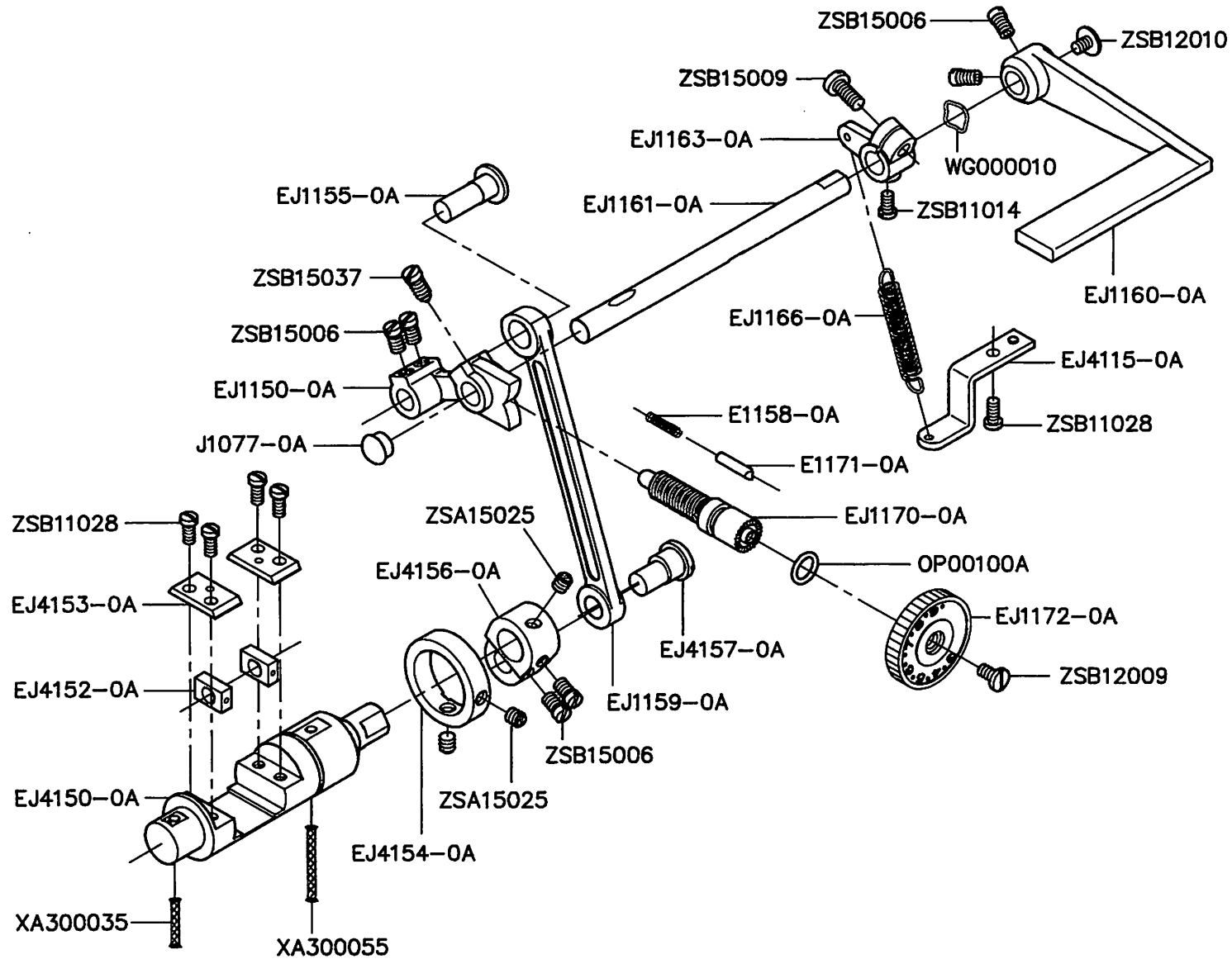

H. CSU-4150.CSU-4250 縫目調整器機構 STITCH REGULATOR MECHANISM

零件號碼 Part No.	零件名稱	Name of Part	件數 4150	Q'TY 4250	備註 Remarks
E1158-0A	壓縮彈簧	Spring	1	1	
E1171-0A	定位銷	Stopper Pin	1	1	
EJ1150-0A	三叉	Feed Regulator	1	1	
EJ1155-0A	偏心調整銷	Eccentric Shaft	1	1	
EJ1159-0A	連接桿	Link	1	1	
EJ1160-0A	倒縫桿	Reverse Lever	1	1	
EJ1161-0A	倒縫軸	Reverse Lever Shaft	1	1	
EJ1163-0A	倒縫軸腕	Reverse Lever Shaft Arm	1	1	
EJ1166-0A	拉伸彈簧	Spring	1	1	
EJ1170-0A	螺桿	Screw-Bar	1	1	
EJ1172-0A	刻度盤	Stitch Length Regulator Dial	1	1	
EJ4115-0A	彈簧固定板	Bracket	1	1	
EJ4150-0A	送料調整器軸	Feed Regulator Shaft	1	1	
EJ4152-0A	滑塊	Feed Regulator Slide Block	2	2	
EJ4153-0A	滑塊導板	Slide Block Guide Plate	2	2	
EJ4154-0A	固定環	Collar	1	1	
EJ4156-0A	倒縫軸連結腕	Reverse Sewing Crank	1	1	
EJ4157-0A	倒縫軸連結銷	Pin	1	1	
J1077-0A	油蓋	Oil Cap	1	1	
OP00100A	O形環	Packing	1	1	
WG000010	波浪形墊圈	Washer	1	1	
XA300035	油線	Oil Wick	1	1	
XA300055	油線	Oil Wick	1	1	
ZSA15025	螺絲	Screw (15/64-28×6)	3	3	
ZSB11014	螺絲	Screw (11/64-40×8.5)	1	1	
ZSB11028	螺絲	Screw (11/64-40×10)	5	5	
ZSB12009	螺絲	Screw (3/16-28×8)	1	1	
ZSB12010	螺絲	Screw (3/16-28×6.5)	1	1	
ZSB15006	螺絲	Screw (15/64-28×8.5)	6	6	
ZSB15009	螺絲	Screw (15/64-28×13)	1	1	
ZSB15037	螺絲	Screw (15/64-28×11.5)	1	1	

I. CSU-4150・CSU-4250 左右送料機構 ZIGZAG FEED MECHANISM

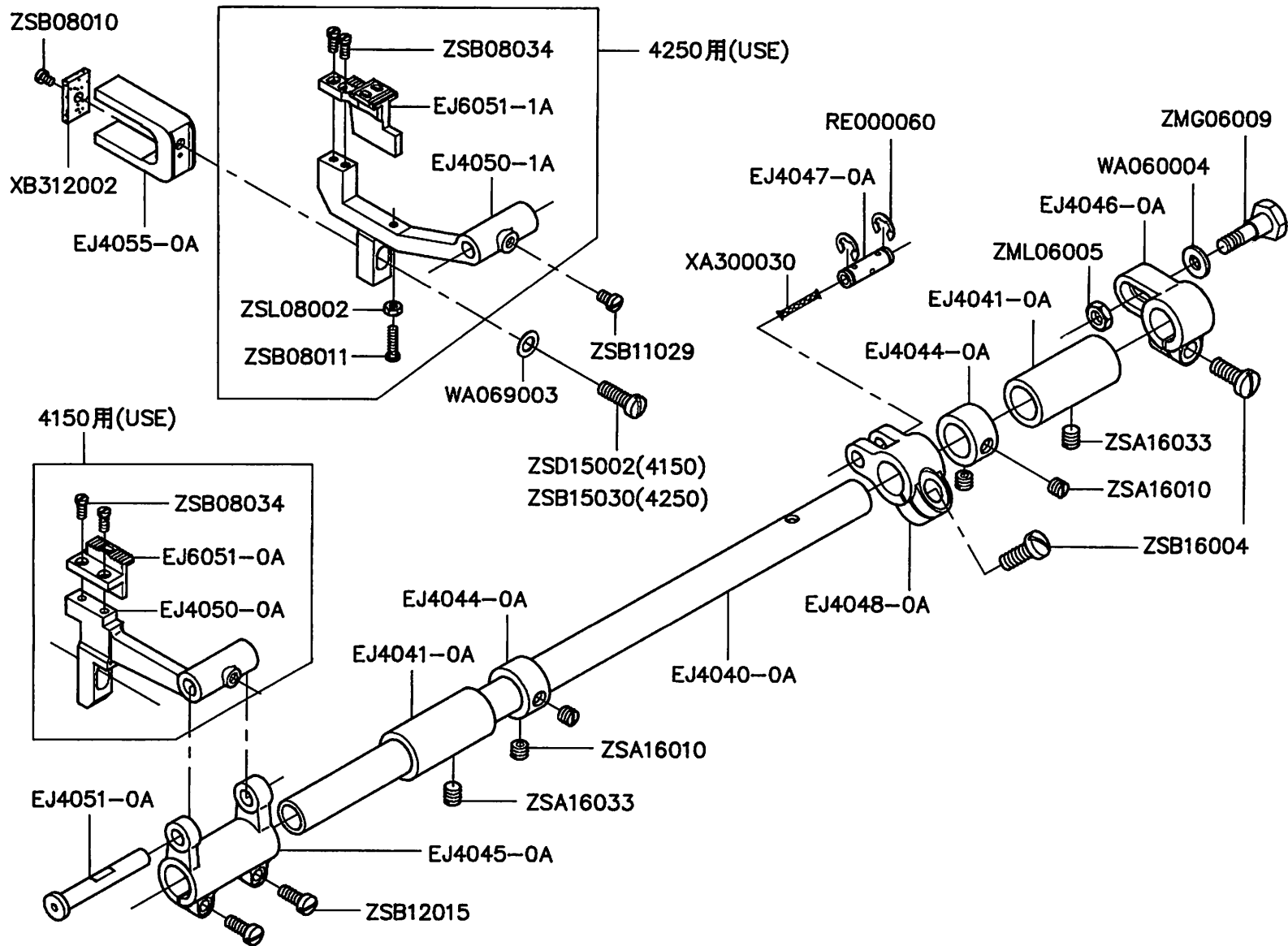

I. CSU-4150.CSU-4250 左右送料機構 ZIGZAG FEED MECHANISM

零件號碼 Part No.	零件名稱	Name of Part	件數 4150	Q'TY 4250	備註 Remarks
EJ4040-0A	送料軸	Feed Rock Shaft	1	1	
EJ4041-0A	送料軸套管	Feed Rock Shaft Bushing,	2	2	
EJ4044-0A	定環	Collar	2	2	
EJ4045-0A	送料軸曲柄(左)	Feed Rock Shaft Crank (Left)	1	1	
EJ4046-0A	送料軸曲柄(右)	Feed Rock Shaft Crank (Right)	1	1	
EJ4047-0A	送料軸曲柄銷	Feed Rock Shaft Crank Pin	1	1	
EJ4048-0A	送料軸曲柄(中)	Feed Rock Shaft Crank (Middle)	1	1	
EJ4050-0A	送料台	Feed Bar	1	0	
EJ4050-1A	送料台	Feed Bar	0	1	
EJ4051-0A	送料台軸	Feed Bar Shaft	1	1	
EJ4055-0A	送料台二又	Feed Bar Fork	1	1	
EJ6051-0A	送料齒	Feed Dog	1	0	
EJ6051-1A	送料齒	Feed Dog	0	1	
RE000060	E形扣環	E-Ring	2	2	
WA060004	平墊圈	Washer	1	1	
WA069003	平墊圈	Washer	1	1	
XA300030	油線	Oil Wick	1	1	
XB312002	油棉	Oil Felt	1	1	
ZMG06009	螺絲	Screw (M6×0.75)	1	1	
ZML06005	螺帽	Nut (M6×0.75×4.8)	1	1	
ZSA16010	螺絲	Screw (1/4-40×4.5)	4	4	
ZSA16033	螺絲	Screw (1/4-24×7.5)	2	2	
ZSB08010	螺絲	Screw (1/8-44×4.6)	1	1	
ZSB08011	螺絲	Screw (1/8-40×13.5)	0	1	
ZSB08034	螺絲	Screw (1/8-40×7)	2	2	
ZSB11029	螺絲	Screw (11/64-40×7)	1	1	
ZSB12015	螺絲	Screw (3/16-28×12)	2	2	
ZSB15030	螺絲	Screw (15/64-28×16.5)	0	1	
ZSB16004	螺絲	Screw (1/4-24×16)	2	2	
ZSD15002	螺絲	Screw (15/64-28×15.5)	1	0	
ZSL08002	螺帽	Nut (1/8-40×2.8)	0	1	

J. CSU-4150・CSU-4250 釜機構 ROTARY HOOK MECHANISM

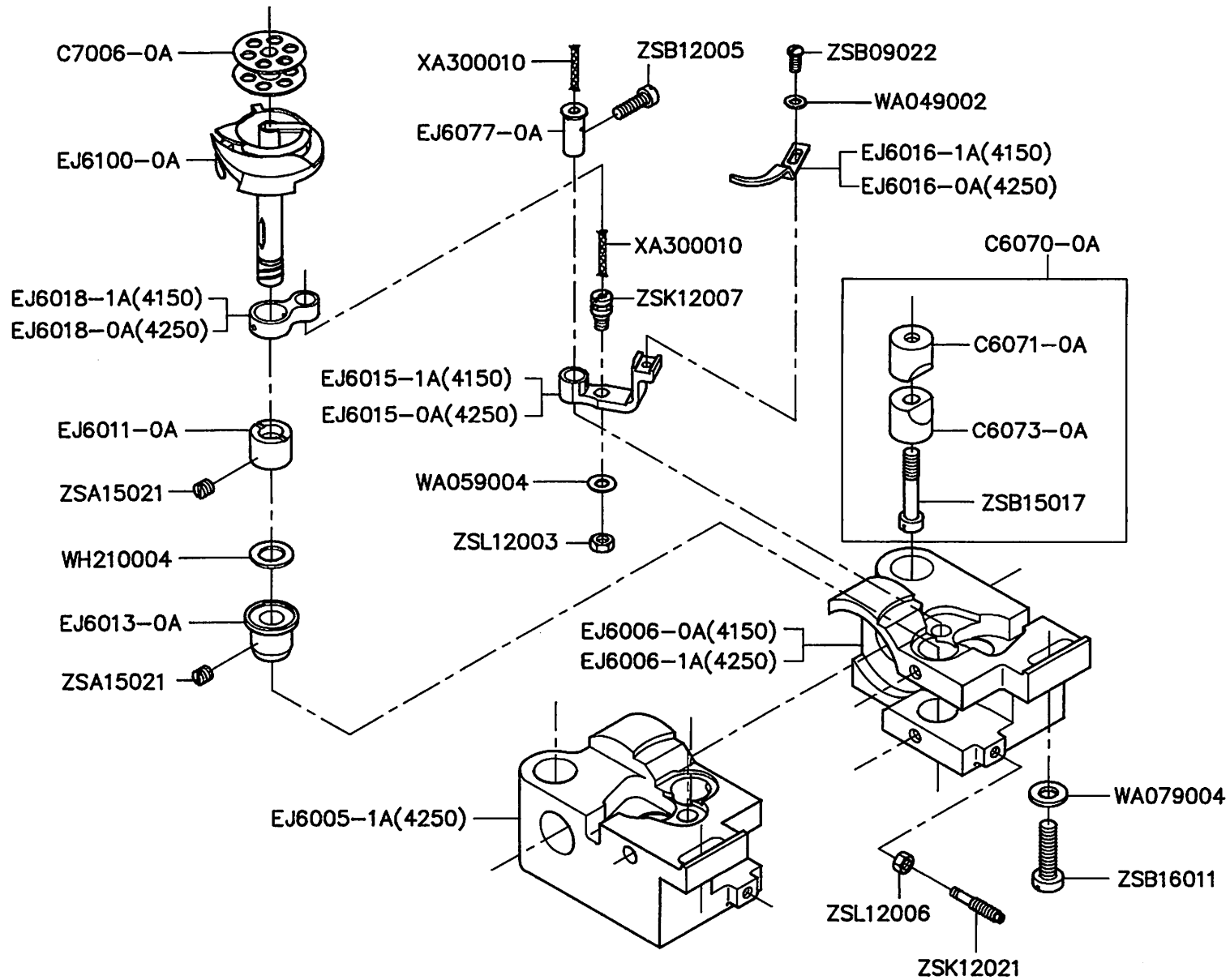

J. CSU-4150.CSU-4250 釜機構 ROTARY HOOK MECHANISM

零件號碼 Part No.	零件名稱	Name of Part	件數 4150	Q'TY 4250	備註 Remarks
C6070-0A	束緊套管組	Pinch Sleeve Assy.	1	2	
C6071-0A	束緊套管(上)	Pinch Sleeve, (Upper)	1	2	
C6073-0A	束緊套管(下)	Pinch Sleeve, (Lower)	1	2	
C7006-0A	梭仔	Bobbin	1	2	
EJ6005-1A	大釜座(左)	Rotary Hook Base, (Left)	0	1	
EJ6006-0A	大釜座(右)	Rotary Hook Base, (Right)	1	0	
EJ6006-1A	大釜座(右)	Rotary Hook Base, (Right)	0	1	
EJ6011-0A	大釜軸套管(上)	Rotary Hook Shaft Bushing, (Upper)	1	2	
EJ6013-0A	大釜軸套管(下)	Rotary Hook Shaft Bushing, (Lower)	1	2	
EJ6015-0A	牛角座	Opener Crank	0	1	
EJ6015-1A	牛角座	Opener Crank	1	0	
EJ6016-0A	牛角	Bobbin Case Opener	0	1	
EJ6016-1A	牛角	Bobbin Case Opener	1	0	
EJ6018-0A	牛角連接器	Opener Link	0	1	
EJ6018-1A	牛角連接器	Opener Link	1	0	
EJ6077-0A	牛角曲柄座桿	Opener Crank Stud	1	2	
EJ6100-0A	梭頭	Rotary Hook Assembly	1	2	
WA049002	平墊圈	Washer	1	2	
WA059004	平墊圈	Washer	1	2	
WA079004	平墊圈	Washer	1	2	
WH210004	平墊圈	Washer	1	2	
XA300010	油線	Wick	2	4	
ZSA15021	螺絲	Screw (15/64-28×4.5)	2	4	
ZSB09022	螺絲	Screw (9/64-40×8)	1	2	
ZSB12005	螺絲	Screw (3/16-28×15)	1	2	
ZSB15017	螺絲	Screw (15/64-28×31.4)	1	2	
ZSB16011	螺絲	Screw (1/4-24×25)	1	2	
ZSK12007	螺絲	Screw (3/16-32)	1	2	
ZSK12021	螺絲	Screw (3/16-28)	1	2	
ZSL12003	螺帽	Nut (3/16-32×3)	1	2	
ZSL12006	螺帽	Nut (3/16-28×3)	1	2	



K. CSU-4150.CSU-4250 下軸機構 LOWER SHAFT MECHANISM

零件號碼 Part No.	零件名稱	Name of Part	件數 Q'TY		備註 Remarks
			4150	4250	
BB6203ZZNR	滾珠軸承	Ball Bearing	1	1	
BNTA2616Z	針狀軸承	Needle Bearing	1	1	
C4025-0A	斜齒輪	Pinion	1	2	
C4026-0A	斜齒輪	Spiral Gear	1	2	
EJ4010-0B	下軸	Lower Shaft	1	1	
EJ4011-0A	下軸套管(左)	Lower Shaft Bushing,(Left)	1	1	
EJ4012-0A	下軸套管(右)	Lower Shaft Bushing,(Right)	1	1	
EJ4014-0A	偏心輪凸輪	Bushing	1	1	
EJ4015-1A	送料偏心輪	Feed eccentric Cam	1	1	
EJ4016-0A	偏心輪	Eccentric Wheel	1	1	
EJ4017-0A	下軸連桿	Level Feed Connecting Rod	1	1	
EJ4018-0A	連接板	Level Feed Connecting Link	1	1	
EJ4020-1A	下軸套管組(中)	Lower Shaft Bushing Complete (Middle)	1	1	
EJ4060-0A	下軸軸承套環	Bearing Holder	1	1	
EJ4061-0A	軸承蓋	Bearing Presser	1	1	
EJ4120-0A	固定銷	Pin	1	1	
EJ4121-0A	彈簧	Spring	1	1	
EJ4151-0A	固定桿	Stud	1	1	
EJ4237-0A	彈簧	Spring	1	1	
EJ4238-0A	彈簧壓板	Spring Holder	1	1	
EJ4240-0A	作動銷	Pin	1	1	
RB200260	C形扣環(軸用)	Retaining Ring	1	1	
RE000050	E形扣環	E-Ring	1	1	
XA300030	油線	Oil Wick	1	1	
XB304001	油棉	Oil Felt	2	2	
ZSA11016	螺絲	Screw (11/64-40×10)	2	2	
ZSA15005	螺絲	Screw (15/64-28×13)	1	1	
ZSA15017	螺絲	Screw (15/64-28×8.5)	1	1	
ZSA16010	螺絲	Screw (1/4-40×4.5)	4	8	
ZSA16020	螺絲	Screw (1/4-40×5.5)	2	4	
ZSA16021	螺絲	Screw (1/4-40×5)	1	1	
ZSA16025	螺絲	Screw (1/4-40×6)	2	2	
ZSB08010	螺絲	Screw (1/8-44×4.6)	1	1	
ZSC09006	螺絲	Screw (9/64-40×8)	3	3	



L. CSU-4150・CSU-4250 油潤滑機構 OIL LUBRICATION MECHANISM

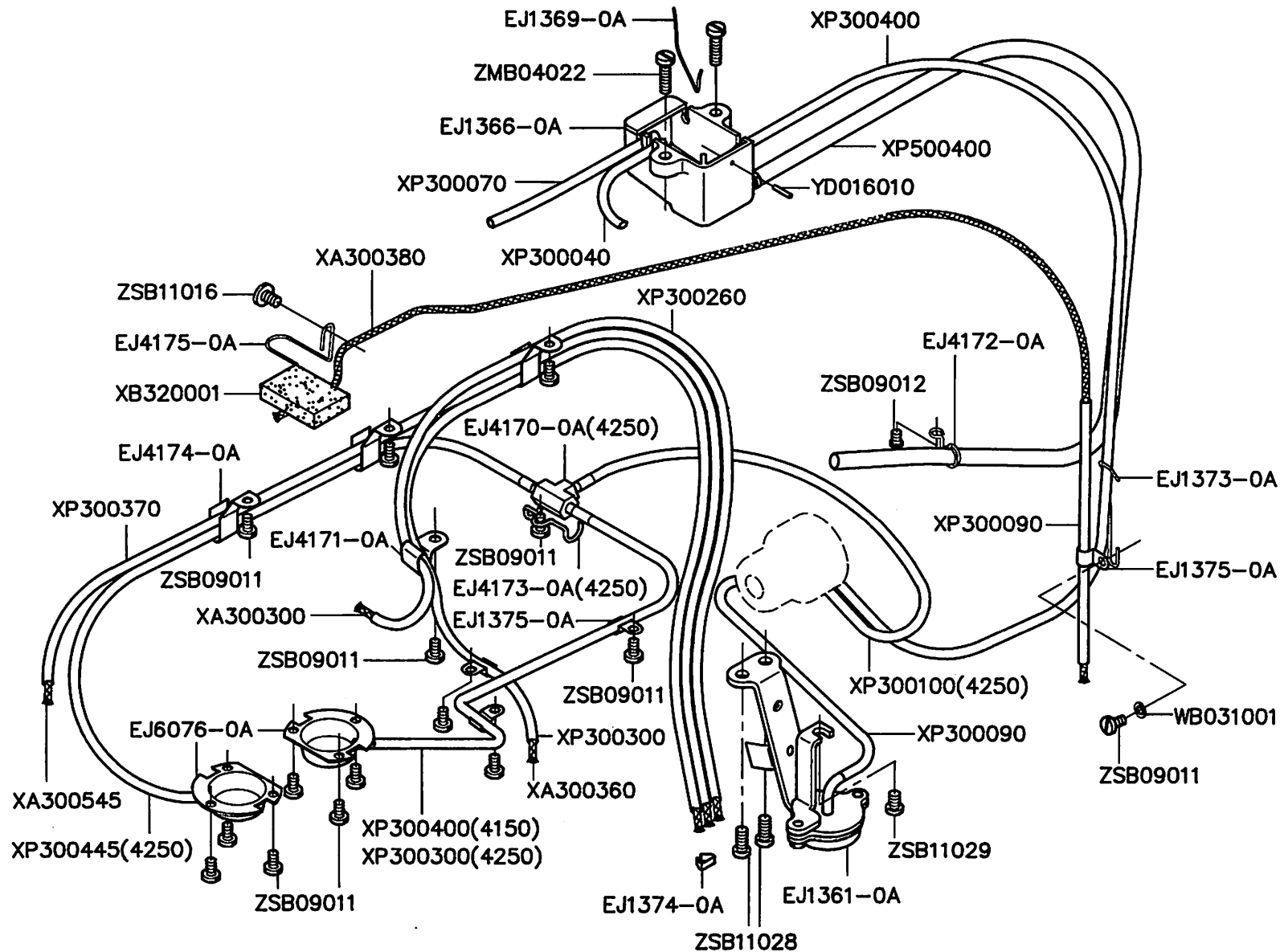

L. CSU-4150.CSU-4250 油潤滑機構 OIL LUBRICATION MECHANISM

零件號碼 Part No.	零件名稱	Name of Part	件數 4150	Q'TY 4250	備註 Remarks
EJ1361-0A	油管固定板組	Mounting Plate Complete	1	1	
EJ1366-0A	油鏡組	Oil Reservoir Complete	1	1	
EJ1369-0A	彈簧	Spring	1	1	
EJ1373-0A	油管固定彈簧	Wire	1	1	
EJ1374-0A	夾線條	Wire Clamp	1	1	
EJ1375-0A	油管壓板	Holder	4	4	
EJ4170-0A	油管接頭	Oil Pipe Joint	0	1	
EJ4171-0A	油管壓板	Holder	1	1	
EJ4172-0A	油管固定彈簧	Wire	1	1	
EJ4173-0A	油管壓條	Holder	0	1	
EJ4174-0A	油管壓板	Holder	3	3	
EJ4175-0A	油棉壓條	Holder	1	1	
EJ6076-0A	油槽組	Oil Reservoir Complete	1	2	
WB031001	彈簧墊圈	Spring Washer	1	1	
XA300300	油線	Oil Wick	1	1	
XA300360	油線	Oil Wick	1	1	
XA300380	油線	Oil Wick	1	1	
XA300545	油線	Oil Wick	1	1	
XB320001	油棉	Oil Felt	1	1	
XP300040	油線管	Oil Tube	1	1	
XP300070	油線管	Oil Tube	1	1	
XP300090	油線管	Oil Tube	2	2	
XP300100	油線管	Oil Tube	0	1	
XP300260	油線管	Oil Tube	1	1	
XP300300	油線管	Oil Tube	1	2	
XP300370	油線管	Oil Tube	1	1	
XP300400	油線管	Oil Tube	2	1	
XP300445	油線管	Oil Tube	0	1	
XP500400	油線管	Oil Tube	1	1	
YD016010	彈簧銷	Spring Pin	1	1	
ZMB04022	螺絲	Screw (M4×0.7×15)	2	2	
ZSB09011	螺絲	Screw (9/64-40×6.5)	11	15	
ZSB09012	螺絲	Screw (9/64-40×4.5)	1	1	
ZSB11016	螺絲	Screw (11/64-40×6.5)	1	1	
ZSB11028	螺絲	Screw (11/64-40×10)	2	2	
ZSB11029	螺絲	Screw (11/64-40×7)	1	1	

M. CSU-4150·CSU-4250 附件 ACCESSORIES

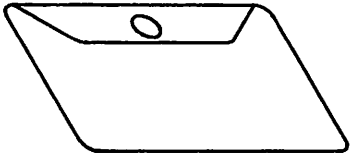

A7000-0A

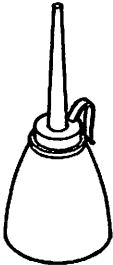

A7012-1A

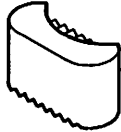

EJ7026-0A



EJ7026-1A

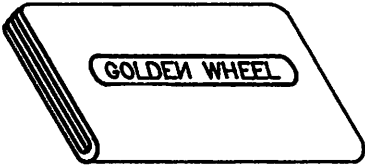

C7001-0A



EJ1021-1A

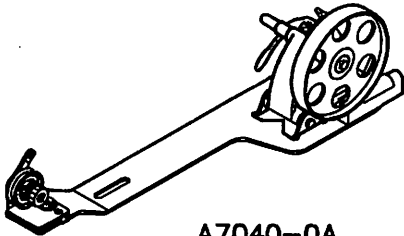

A7040-0A



A7025-0A

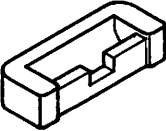

F7022-0A

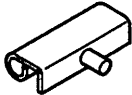

F7021-0A



ZMT05001



WA059003



A7010-1A



A7010-0A

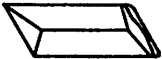

INDP×17#23



A7011-0A

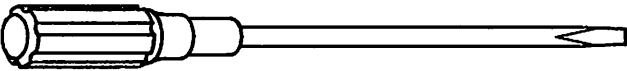

A7010-2A



C7006-0A

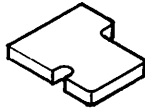

EJ7042-0A

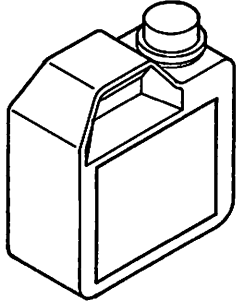

EH7012-0A

M. CSU-4150.CSU-4250 附件 ACCESSORIES

零件號碼 Part No.	零件名稱	Name of Part	件數 4150	Q'TY 4250	備註 Remarks
A7000-0A	工具袋	Accessory Bag	1	1	
A7010-0A	螺絲起子(小)	Screw Driver (Small)	1	1	
A7010-1A	螺絲起子(中)	Screw Driver (Middle)	1	1	
A7010-2A	螺絲起子(大)	Screw Driver (Large)	1	1	
A7011-0A	鐵釘	Nail	15	15	
A7012-1A	油壺(中)	Oiler (Middle)	1	1	
A7025-0A	枕木	Head Rest Wood	1	1	
A7040-0A	捲線器組	Bobbin Winder	1	1	
C7001-0A	車頭蓋	Vinyl Cover	1	1	
C7006-0A	梭仔	Bobbin	4	4	
EH7012-0A	油壺(大)	Oiler (Large)	1	1	
EJ1021-1A	調整彈簧	Tension Spring	1	2	
EJ7026-0A	橡膠墊	Head Cushion	2	2	
EJ7026-1A	橡膠墊座	Head Cushion	2	2	
EJ7042-0A	濾網	Felt	1	1	
F7021-0A	後鈕釦	Head Hinge	2	2	
F7022-0A	後鈕座	Rubber Hinge	2	2	
INDP×17#23	針	Needle	4	4	
WA059003	平墊圈	Washer	2	2	
ZMT05001	螺絲	Screw (4.5×20)	2	2	

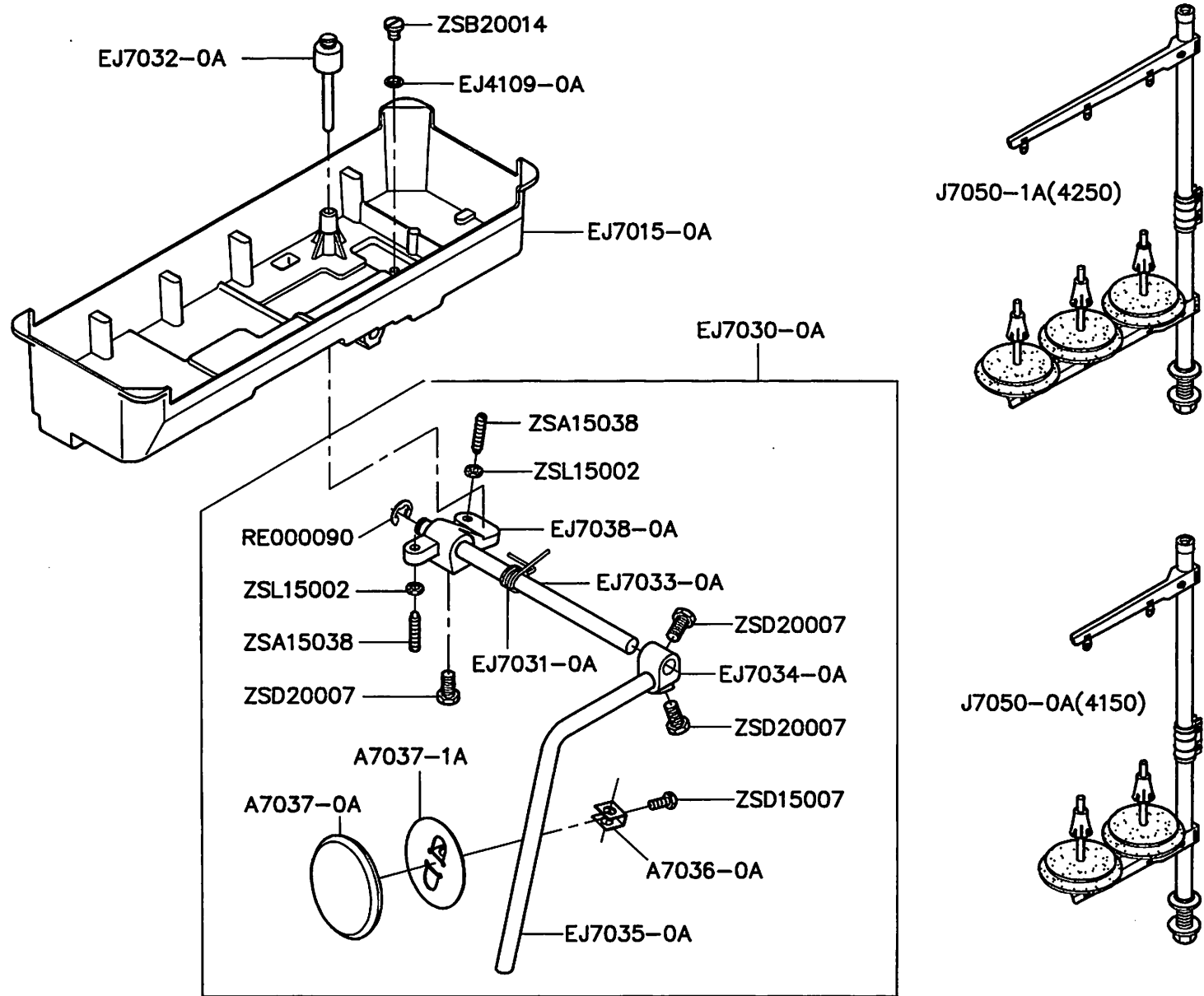

M. CSU-4150·CSU-4250 附件 ACCESSORIES



M. CSU-4150.CSU-4250 附件 ACCESSORIES

零件號碼 Part No.	零件名稱	Name of Part	件數 4150	Q'TY 4250	備註 Remarks
A7036-0A	固定支架	Retainer	1	1	
A7037-0A	海棉墊	Knee Guard	1	1	
A7037-1A	腳弓大餅	Knee Plate	1	1	
EJ4109-0A	墊圈	Washer	1	1	
EJ7015-0A	下油槽	Oil Pan	1	1	
EJ7030-0A	腳弓組	Knee Lifter Assy.	1	1	
EJ7031-0A	彈簧	Spring	1	1	
EJ7032-0A	腳押聯桿頭	Knee Lifter Pin	1	1	
EJ7033-0A	腳押直桿	Knee Lever Rod	1	1	
EJ7034-0A	連接器	Clamp	1	1	
EJ7035-0A	腳押曲桿	Knee Lever Rod	1	1	
EJ7038-0A	連接器	Clamp	1	1	
J7050-0A	線架	Thread Stand	1	0	
J7050-1A	線架	Thread Stand	0	1	
RE000090	E形扣環	E-Ring	1	1	
ZSA15038	螺絲	Screw (15/64-28×28)	2	2	
ZSB20014	螺絲	Screw (5/16-28×9.3)	1	1	
ZSD15007	螺絲	Screw (15/64-28×14)	1	1	
ZSD20007	螺絲	Screw (5/16-18×16)	3	3	
ZSL15002	螺帽	Nut (15/64-28×3)	2	2	

N. CSU-4250 針位圖號詳表 GAUGE PARTS LIST

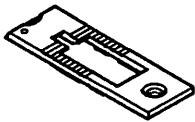
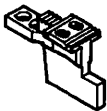
					
規格 SPECIFICATION in ( m/m )	EJ1075-1A 針 留 NEEDLE CLAMP	EJ1235-1A 外 押 腳 WALKING FOOT	EJ1237-1A 內 押 腳 PRESSER FOOT	EJ6050-1A 針 板 NEEDLE PLATE	EJ6051-1A 送 料 齒 FEED DOG
1/8 (3.2)	EJ1075-041A	EJ1235-041A	EJ1237-041A	EJ6050-041A	EJ6051-041A
5/32 (4.0)	EJ1075-051A	EJ1235-051A	EJ1237-051A	EJ6050-051A	EJ6051-051A
3/16 (4.8)	EJ1075-061A	EJ1235-061A	EJ1237-061A	EJ6050-061A	EJ6051-061A
1/4 (6.4)	EJ1075-081A	EJ1235-081A	EJ1237-081A	EJ6050-081A	EJ6051-081A
5/16 (8.0)	EJ1075-101A	EJ1235-101A	EJ1237-101A	EJ6050-101A	EJ6051-101A
3/8 (9.5)	EJ1075-121A	EJ1235-121A	EJ1237-121A	EJ6050-121A	EJ6051-121A
1/2 (12.7)	EJ1075-161A	EJ1235-161A	EJ1237-161A	EJ6050-161A	EJ6051-161A
5/8 (16.0)	EJ1075-181A	EJ1235-181A	EJ1237-181A	EJ6050-181A	EJ6051-181A
3/4 (19.0)	EJ1075-201A	EJ1235-201A	EJ1237-201A	EJ6050-201A	EJ6051-201A
1 (25.4)	EJ1075-231A	EJ1235-231A	EJ1237-231A	EJ6050-231A	EJ6051-231A

0. CSU-4150.CSU-4250 零件號碼與頁數對照表 NUMERICAL PARTS-LIST

零件號碼 Part No.	頁數 PAGE	零件號碼 Part No.	頁數 PAGE	零件號碼 Part No.	頁數 PAGE	零件號碼 Part No.	頁數 PAGE
A1024-1A	-- 4	B4138-0A	-- 6	EJ1027-1A	-- 4	EJ1208-0A	-- 12
A1026-1A	-- 4	BB6203ZZNR-	22	EJ1028-0A	-- 4	EJ1235-0A	-- 12
A1026-3A	-- 4	BB6204ZZNR-	6	EJ1028-2A	-- 4	EJ1235-1A	-- 12
A1030-0A	-- 4	BNTA2616Z--	22	EJ1037-0A	-- 4	EJ1237-0A	-- 12
A1031-0A	-- 4	C1041-0A	-- 2	EJ1043-0A	-- 4	EJ1237-1A	-- 12
A1032-0A	-- 4	C1052-0A	-- 2	EJ1051-0A	-- 2	EJ1272-0A	-- 12
A1033-0A	-- 4	C1054-0A	-- 2	EJ1055-2A	-- 2	EJ1273-0A	-- 12
A1034-0A	-- 4	C1062-0A	-- 8	EJ1060-0A	-- 8	EJ1278-0A	-- 2
A1035-0A	-- 4	C1183-0A	-- 12	EJ1063-0A	-- 2	EJ1280-0A	-- 12
A1036-0A	-- 4	C4025-0A	-- 22	EJ1070-0A	-- 8	EJ1281-0A	-- 12
A1038-0A	-- 4	C4026-0A	-- 22	EJ1070-1A	-- 8	EJ1282-0A	-- 12
A1061-0A	-- 8	C6070-0A	-- 20	EJ1074-0A	-- 8	EJ1283-0A	-- 12
A1077-0A	-- 2	C6071-0A	-- 20	EJ1075-1A	-- 8	EJ1284-0A	-- 12
A1105-0A	-- 6	C6073-0A	-- 20	EJ1080-0A	-- 8	EJ1285-0A	-- 8
A1107-0A	-- 8	C7001-0A	-- 26	EJ1081-0A	-- 8	EJ1286-0A	-- 12
A1130-0A	-- 14	C7006-0A	-- 20, 26	EJ1090-0A	-- 8	EJ1287-0A	-- 12
A7000-0A	-- 26	E1158-0A	-- 16	EJ1091-0A	-- 8	EJ1290-0A	-- 14
A7010-0A	-- 26	E1171-0A	-- 16	EJ1092-0A	-- 8	EJ1291-0A	-- 14
A7010-1A	-- 26	E1297-0A	-- 14	EJ1100-0A	-- 6	EJ1295-0A	-- 14
A7010-2A	-- 26	E1298-0A	-- 14	EJ1101-0A	-- 6	EJ1300-0A	-- 14
A7011-0A	-- 26	EH7012-0A	-- 26	EJ1103-0A	-- 6	EJ1301-0A	-- 14
A7012-1A	-- 26	EJ1010-0A	-- 2	EJ1106-1A	-- 6	EJ1305-0A	-- 14
A7025-0A	-- 26	EJ1010-1A	-- 2	EJ1150-0A	-- 16	EJ1307-0A	-- 14
A7036-0A	-- 28	EJ1011-0A	-- 2	EJ1155-0A	-- 16	EJ1320-0B	-- 6
A7037-0A	-- 28	EJ1011-1A	-- 2	EJ1159-0A	-- 16	EJ1322-0A	-- 6
A7037-1A	-- 28	EJ1012-0A	-- 2	EJ1160-0A	-- 16	EJ1323-0A	-- 6
A7040-0A	-- 26	EJ1014-0A	-- 2	EJ1161-0A	-- 16	EJ1331-0A	-- 10
B1076-0A	-- 8	EJ1017-0A	-- 2	EJ1163-0A	-- 16	EJ1332-0A	-- 10
B1274-0A	-- 12	EJ1020-0A	-- 4	EJ1166-0A	-- 16	EJ1333-0A	-- 10
B1275-0A	-- 12	EJ1020-1A	-- 4	EJ1170-0A	-- 16	EJ1334-0A	-- 10
B1283-0A	-- 12	EJ1021-0A	-- 4	EJ1172-0A	-- 16	EJ1335-0A	-- 10
B1321-0A	-- 6	EJ1021-1A	-- 26	EJ1180-0A	-- 12	EJ1336-0A	-- 10
B4131-0A	-- 6	EJ1026-0A	-- 4	EJ1192-0A	-- 14	EJ1337-0A	-- 10
B4133-0A	-- 6	EJ1026-2A	-- 4	EJ1193-0A	-- 14	EJ1341-0A	-- 10
B4135-0A	-- 6	EJ1027-0A	-- 4	EJ1200-0A	-- 12	EJ1343-0A	-- 10



0. CSU-4150.CSU-4250 零件號碼與頁數對照表 NUMERICAL PARTS-LIST

零件號碼 Part No.	頁數 PAGE	零件號碼 Part No.	頁數 PAGE	零件號碼 Part No.	頁數 PAGE	零件號碼 Part No.	頁數 PAGE
EJ1344-0A--	10	EJ4109-0A--	28	EJ6018-1A--	20	WA049002	-- 20
EJ1361-0A--	24	EJ4115-0A--	16	EJ6049-0A--	10	WA059002	-- 8
EJ1366-0A--	24	EJ4120-0A--	22	EJ6050-0A--	10	WA059003	-- 26
EJ1369-0A--	24	EJ4121-0A--	22	EJ6050-1A--	10	WA059004	-- 20
EJ1373-0A--	24	EJ4130-0B--	6	EJ6051-0A--	18	WA060004	-- 18
EJ1374-0A--	24	EJ4132-0A--	6	EJ6051-1A--	18	WA069001	-- 14
EJ1375-0A--	24	EJ4134-0A--	6	EJ6076-0A--	24	WA069003	-- 18
EJ4010-0B--	22	EJ4136-0A--	6	EJ6077-0A--	20	WA079004	-- 20
EJ4011-0A--	22	EJ4137-0A--	6	EJ6100-0A--	20	WB031001	-- 24
EJ4012-0A--	22	EJ4150-0A--	16	EJ7015-0A--	28	WG000010	-- 16
EJ4014-0A--	22	EJ4151-0A--	22	EJ7026-0A--	26	WH210004	-- 20
EJ4015-1A--	22	EJ4152-0A--	16	EJ7026-1A--	26	XA300010	-- 20
EJ4016-0A--	22	EJ4153-0A--	16	EJ7030-0A--	28	XA300030	-- 8, 18, 22
EJ4017-0A--	22	EJ4154-0A--	16	EJ7031-0A--	28	XA300035	-- 16
EJ4018-0A--	22	EJ4156-0A--	16	EJ7032-0A--	28	XA300040	-- 8
EJ4020-1A--	22	EJ4157-0A--	16	EJ7033-0A--	28	XA300055	-- 16
EJ4040-0A--	18	EJ4170-0A--	24	EJ7034-0A--	28	XA300065	-- 8
EJ4041-0A--	18	EJ4171-0A--	24	EJ7035-0A--	28	XA300080	-- 8
EJ4044-0A--	18	EJ4172-0A--	24	EJ7038-0A--	28	XA300085	-- 10
EJ4045-0A--	18	EJ4173-0A--	24	EJ7042-0A--	26	XA300240	-- 8
EJ4046-0A--	18	EJ4174-0A--	24	F7021-0A	-- 26	XA300300	-- 24
EJ4047-0A--	18	EJ4175-0A--	24	F7022-0A	-- 26	XA300360	-- 24
EJ4048-0A--	18	EJ4237-0A--	22	INDP× 17#23	8, 26	XA300380	-- 24
EJ4050-0A--	18	EJ4238-0A--	22	J1077-0A	-- 16	XA300545	-- 24
EJ4050-1A--	18	EJ4240-0A--	22	J7050-0A	-- 28	XB118001	-- 6
EJ4051-0A--	18	EJ6005-1A--	20	J7050-1A	-- 28	XB206003	-- 8, 14
EJ4055-0A--	18	EJ6006-0A--	20	OP00100A	-- 16	XB304001	-- 22
EJ4060-0A--	22	EJ6006-1A--	20	RB200250	-- 14	XB308002	-- 2
EJ4061-0A--	22	EJ6011-0A--	20	RB200260	-- 22	XB312002	-- 18
EJ4080-0A--	10	EJ6013-0A--	20	RE000025	-- 6	XB320001	-- 24
EJ4080-1A--	10	EJ6015-0A--	20	RE000050	-- 22	XP300040	-- 24
EJ4081-0A--	10	EJ6015-1A--	20	RE000060	-- 18	XP300070	-- 24
EJ4081-1A--	10	EJ6016-0A--	20	RE000090	-- 28	XP300090	-- 24
EJ4082-0A--	10	EJ6016-1A--	20	S1013-0A	-- 2	XP300100	-- 24
EJ4085-0A--	2	EJ6018-0A--	20	S1014-0A	-- 2	XP300260	-- 24

0. CSU-4150.CSU-4250 零件號碼與頁數對照表 NUMERICAL PARTS-LIST

零件號碼 Part No.	頁數 PAGE	零件號碼 Part No.	頁數 PAGE	零件號碼 Part No.	頁數 PAGE	零件號碼 Part No.	頁數 PAGE
XP300300	-- 24	ZSA16033	-- 10,18	ZSB11041	-- 2	ZSG09004	-- 4
XP300370	-- 24	ZSA16034	-- 6,12	ZSB11069	-- 12	ZSG09005	-- 4
XP300400	-- 24	ZSB06001	-- 4	ZSB11083	-- 12	ZSG16003	-- 14
XP300445	-- 24	ZSB06002	-- 8	ZSB12005	-- 20	ZSG16005	-- 14
XP500400	-- 24	ZSB06003	-- 4	ZSB12009	-- 16	ZSG16018	-- 12
YB040025	-- 10	ZSB08002	-- 8	ZSB12010	-- 16	ZSG16019	-- 14
YC016012	-- 14	ZSB08010	-- 18,22	ZSB12015	-- 18	ZSK11036	-- 12
YD016010	-- 24	ZSB08011	-- 18	ZSB15004	-- 6	ZSK12007	-- 20
ZMB04022	-- 24	ZSB08034	-- 18	ZSB15006	-- 6,16	ZSK12021	-- 20
ZMG06003	-- 14	ZSB09005	-- 2	ZSB15009	-- 16	ZSK16007	-- 14
ZMG06009	-- 18	ZSB09007	-- 4	ZSB15017	-- 20	ZSK16031	-- 14
ZML06001	-- 14	ZSB09011	-- 2,24	ZSB15030	-- 18	ZSL08002	-- 18
ZML06005	-- 18	ZSB09012	-- 24	ZSB15037	-- 16	ZSL09001	-- 4
ZMT05001	-- 26	ZSB09022	-- 20	ZSB15041	-- 6	ZSL12003	-- 20
ZSA11005	-- 10	ZSB09023	-- 10	ZSB16004	-- 10,18	ZSL12006	-- 20
ZSA11016	-- 22	ZSB09027	-- 8	ZSB16011	-- 20	ZSL15002	-- 28
ZSA13002	-- 10	ZSB09028	-- 12	ZSB18001	-- 6	ZSL16004	-- 14
ZSA15005	-- 22	ZSB09032	-- 8	ZSB18002	-- 6	ZSL20004	-- 10
ZSA15006	-- 8	ZSB10002	-- 12	ZSB20009	-- 12	ZSN16002	-- 4
ZSA15017	-- 6,8,22	ZSB11008	-- 2	ZSB20014	-- 28		
ZSA15018	-- 6	ZSB11010	-- 8	ZSC06005	-- 8		
ZSA15021	-- 6,20	ZSB11012	-- 2,4	ZSC09006	-- 22		
ZSA15025	-- 16	ZSB11014	-- 16	ZSC09009	-- 2		
ZSA15028	-- 14	ZSB11016	-- 24	ZSC09021	-- 2		
ZSA15038	-- 28	ZSB11017	-- 12	ZSC11002	-- 10		
ZSA16010	-- 6,18,22	ZSB11020	-- 12	ZSD11001	-- 8		
ZSA16011	-- 14	ZSB11026	-- 2	ZSD15002	-- 18		
ZSA16020	-- 22	ZSB11028	-- 16,24	ZSD15007	-- 28		
ZSA16021	-- 22	ZSB11029	-- 18,24	ZSD16007	-- 14		
ZSA16025	-- 6,22	ZSB11030	-- 14	ZSD20007	-- 28		